



www.gotowti.com

An ISO 9001:2000 Certified Company



Wireless Technology, Inc.

**V-MAX III G
5.8 GHz
TRANSMISSION SYSTEMS**

*Installation and
Operation Manual*

TABLE OF CONTENTS

INFORMATION	Page 3
PRODUCT WARRANTY AND REPAIRS	Page 4
REPAIR AUTHORIZATION	Page 5
SAFEGUARDS & TOOLS	Page 6
INTRODUCTION	Page 7
V-MAX III G TRANSMITTER	Page 8
V-MAX III G RECEIVER	Page 9
ANTENNAS	Page 10
INSTALLATION	Page 11
32 CHANNEL TRANSMITTER & RECEIVER SETTINGS	Page 12
TROUBLE SHOOTING	Page 14
SPECIFICATIONS	Page 15

INFORMATION

READ THIS MANUAL

Every effort has been made to insure that this WTI system is of the highest quality. This product has been carefully inspected to comply with rigid quality standards before shipment to you. In consideration of your investment and the desire to obtain full performance capability engineered into your new WTI product, we recommend that you read this manual before attempting to operate your system.

FOR MORE ASSISTANCE OR MORE INFORMATION:

Wireless Technology, Inc. (WTI)
2064 Eastman Avenue, Suite 113
Ventura, CA 93003-7787

TEL 805/339-9696

FAX 805/339-0932

EMAIL: sales@wirelesstech.com

INTERNET: <http://www.gotowti.com>

The software/firmware furnished with the equipment is confidential to and is copyrighted by *Wireless Technology, Inc.* (WTI) It is not to be copied or disclosed in any manner without the consent of *Wireless Technology, Inc.* (WTI) The software/firmware is furnished to the purchaser under a license for use on a single system.

Information furnished by *Wireless Technology, Inc.* (WTI) is believed to be accurate and reliable. However, no responsibility is assumed by *Wireless Technology, Inc.* (WTI) for its use or for any infringements of other rights of third parties, which may result from its use. No license is granted by implications or otherwise under any patent or patent rights of *Wireless Technology, Inc.* (WTI)

©2005 Wireless Technology, Inc. (WTI)
All rights reserved.

PRODUCT WARRANTY AND REPAIR

PRODUCT WARRANTY

We appreciate your purchase of *Wireless Technology, Inc.* (WTI) security products. We take pride in the quality of our products and have manufactured each new WTI product to exacting quality standards. In normal use, it will provide you with years of satisfactory performance. However, should you experience difficulty; you are protected under the provisions of this warranty.

WTI warrants to the original user a product that is free of defects in materials and workmanship in normal use. WTI warrants to the original user that WTI's wireless RF transmission system products will be free of defects in materials and workmanship in normal use for a period of 12 months from the date of sale. WTI's obligation under this warranty shall be limited to the repair, including all necessary parts and the cost of labor connected therewith, or at our option, the replacement of any product that shows evidence of a manufacturing defect within the warranty period.

This warranty is extended to all WTI products purchased and used within the United States of America and is valid only when service is rendered by the authorized *Wireless Technology, Inc.* (WTI) Warranty Station.

This warranty shall not apply to appearance or accessory items including, but not limited to, knobs, connectors, cabinets and connecting cables. This warranty shall not, in addition, apply to repairs or replacements necessitated by any cause beyond the control of WTI including, but not limited to, acts of nature, improper installation, misuse, lack of proper maintenance, accident, voltage fluctuations, unauthorized repairs or modifications.

This warranty becomes void in the event serial numbers are altered, defaced or removed, or an attempt is made to field service or alter performance of any RF transmission component.

WTI reserves the right to make changes in design, or to make additions to, or improvements upon, products without incurring any obligation to install the same on products previously manufactured.

The foregoing is in lieu of all other warranties expressed or implied and WTI neither assumes nor authorizes any person to assume for it any other obligation or liability in connection with the sale of our products. In no event shall WTI or its Authorized Dealers be liable for special or consequential damage arising from the use of this product, or any delay in the performance of this warranty due to causes beyond its control.

PRODUCT WARRANTY AND REPAIR

REPAIR AUTHORIZATION

Please contact *Wireless Technology, Inc.* (WTI), to obtain a repair authorization number (RA) and provide the following information:

- 1.) Product Model & Serial Numbers
- 2.) Date of shipment, purchase order number, sales order number or WTI invoice number.
- 3.) Details of the defect or malfunction. If there is a dispute regarding the warranty or product, which does not fall under the warranty conditions stated within the description of the written warranty, please include a written explanation with the product when returned.

SHIP FREIGHT PRE-PAID TO:
Wireless Technology, Inc. (WTI)
2064 Eastman Avenue, Suite 113
Ventura, CA 93003-7787
TEL 805/339-9696
FAX 805/339-0932

RETURNS

No unauthorized returns will be accepted. All returns must have an authorized (RA) number issued by the factory (CA number if returned for credit and RA number if returned for repair). Products returned for repair or credit will be rejected if no authorization number has been issued or freight has not been pre-paid. All merchandise returned for credit will be subject to a 20% restocking and refurbishing charge.

SAFEGUARDS AND TOOLS

IMPORTANT SAFEGUARDS

- 1.) Read Instructions. It is important to read all safety and operating instructions before installing or using this equipment.
- 2.) Retain Instructions. Retain this manual and any supplements for future reference.
- 3.) Follow Instructions. Follow all instructions herein for use of this equipment.

Do not attempt to open the sealed Transmitter and Receiver Assembly. There are no user-serviceable parts inside. Refer servicing to the *Wireless Technology, Inc. (WTI) factory service center only.*

- 4.) Heed warnings. Adhere to all warnings on the equipment, and in this manual.
- 5.) To reduce the risk of electric shock or equipment damage, work on the unit only when the power is shut off and is unplugged from its power source to prevent accidental activation. Also take precautions to avoid contact between the equipment and other electrical wires or power sources that may be present at the installation site.

RECOMMENDED TOOLS AND ACCESSORIES FOR PROPER INSTALLATION:

- 1.) Tie-wraps to secure cable runs
- 2.) #1 and #2 Phillips screwdriver
- 3.) #3 Slot screwdriver
- 4.) Cordless power drill
- 5.) Set of open end or SAE wrenches
- 6.) Silicone caulking compound for antenna connector
- 7.) Self-sealing connector tape - Used to weatherproof all outdoor cable connections
- 8.) Appropriate conduit if boxes are mounted outdoors.
- 9.) Hand held radios

Wireless Technology, Inc. (WTI) recommends the use of RG59/U such as Belden 8241 or equivalent 75Ω coaxial cable with 22-gauge solid copper center conductor and foam polyethylene dielectric. Either RG6/U or RG11/U would make an excellent substitute.

Long coaxial cable runs cause signal degradation and/ or “SYNC” discrepancies. Limit RG59/U cable lengths to 800 feet. For coaxial runs from 800 feet to 1000 feet, use RG6/U or RG11/U.

Do not use screw on type BNC connectors. They are not suited for reliable installations.

INTRODUCTION

V-MAX III G SERIES VIDEO TRANSMISSION SYSTEMS

Following in the tradition of *Wireless Technology's* successful microwave video transmission systems; the V-MAX III G offers an unprecedented level of performance. The V-MAX III G provides high resolution, real-time video transmission and reception in the most hostile environments.

V-MAX III G 5.8 GHz SERIES FEATURES

- 32 field selectable operating frequencies.
- High density co-location potential.
- No software required for system set-up.
- Systems are shipped complete - No extras to purchase.
- Optional thermostatically controlled heater.
- Seamless operation with any "Wireless" PTZ camera control / data system.
- Utilizes high-technology microstrip and dish antennas.
- V-MAX III G employs an ultra low noise receiver front end.
- V-MAX III G receiver utilizes a 5 pole low loss filtering stage.

V-MAX III G TRANSMITTER

V-MAX III G SERIES VIDEO TRANSMISSION SYSTEMS

V-MAX III G Transmitter

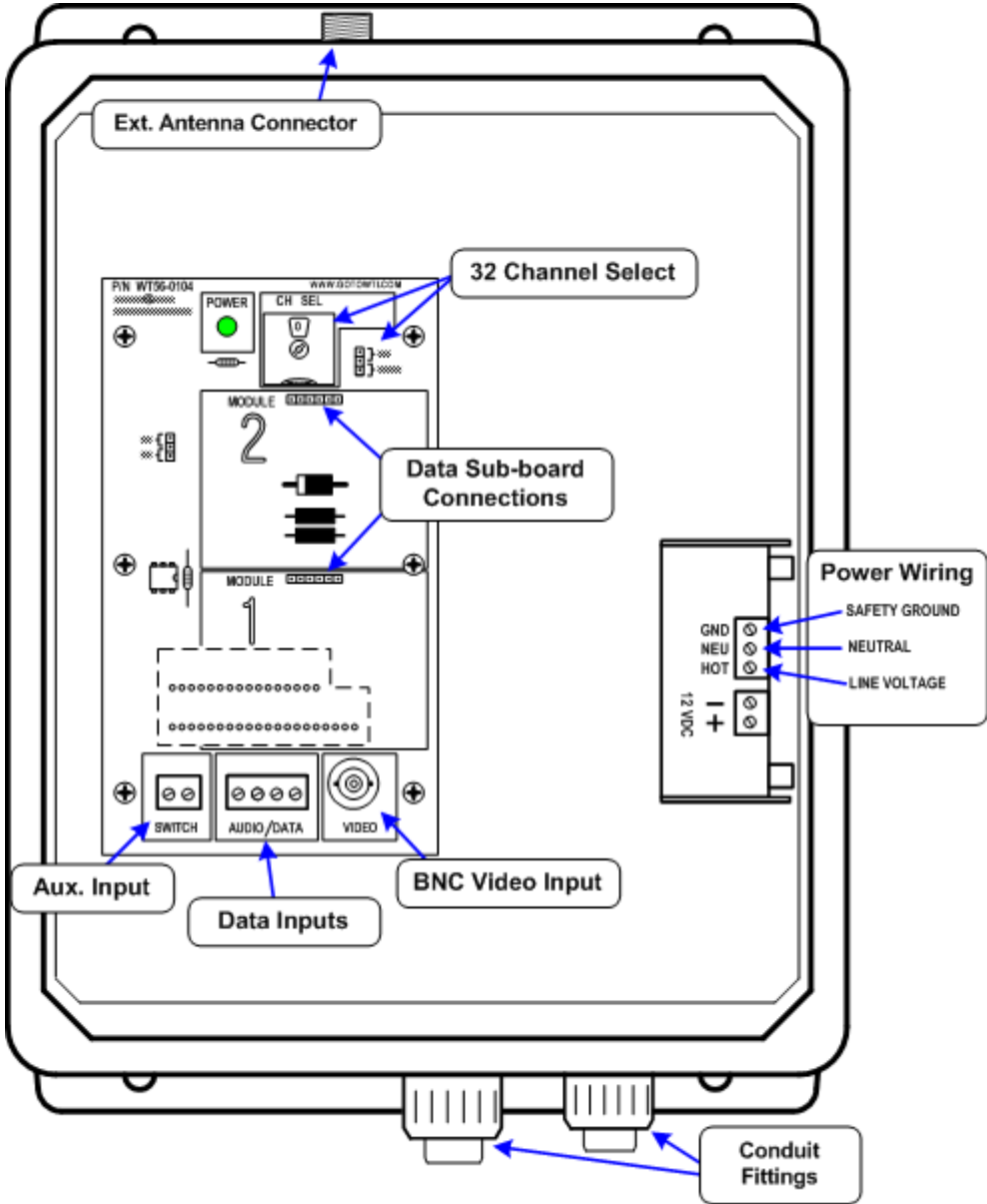

V-MAX III G RECEIVER

V-MAX III G SERIES VIDEO TRANSMISSION SYSTEMS

V-MAX III G Receiver

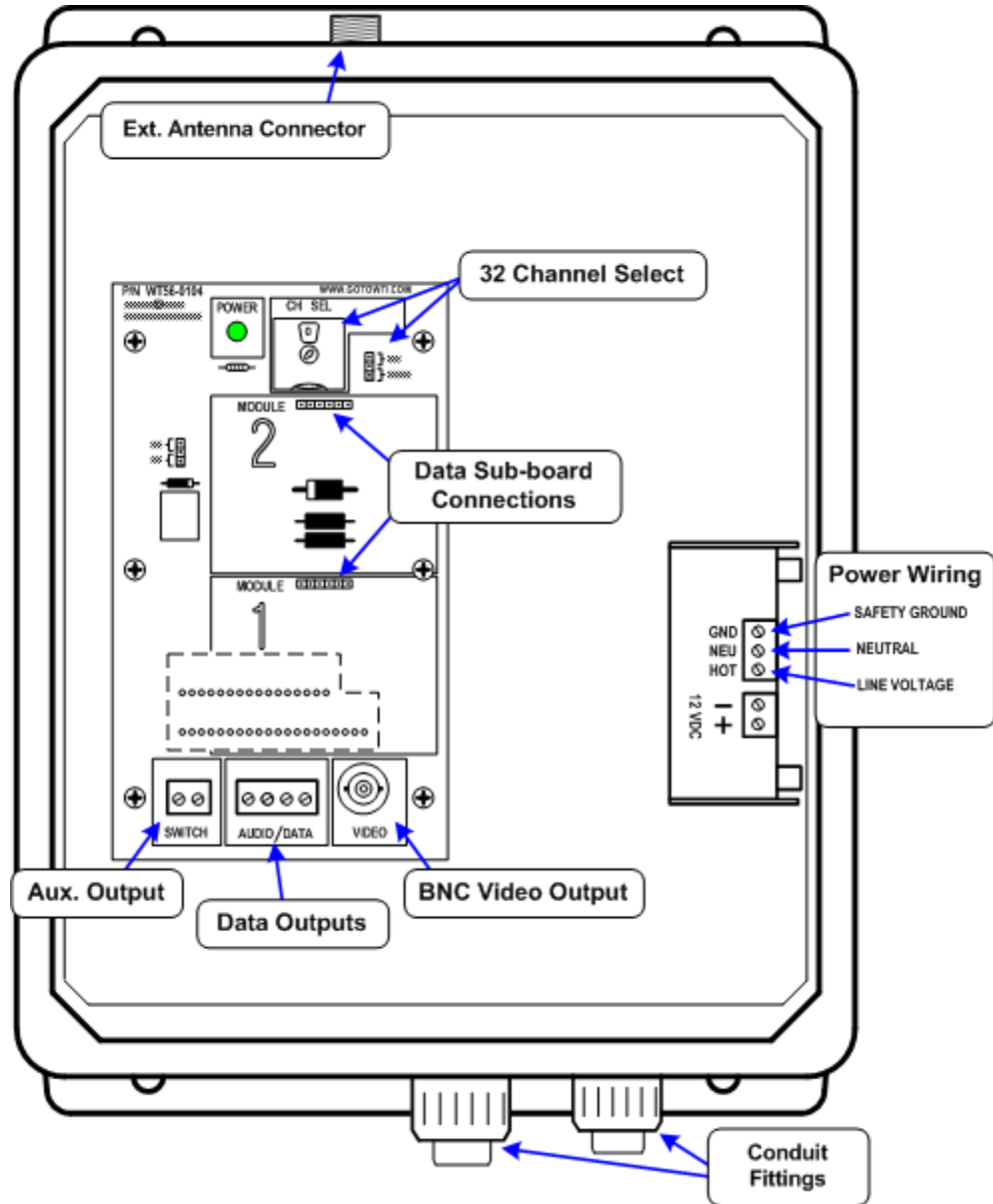

V-MAX III G SERIES VIDEO TRANSMISSION SYSTEMS



**V-MAX III G Series Transmitter/Receiver Antenna
Integral Antenna**



**V-MAX III G Series Transmitter/Receiver Antenna
Parabolic Dish Antenna (16")**



































































**V-MAX III G Series Transmitter/Receiver Antenna
Parabolic Dish Antenna (24")**

































































INSTALLATION

1. Mount the V-MAX III G Series transmitter and receiver enclosures in place using the stainless steel worm drive clamps provided, keeping away from electronically noisy items. Insure that the V-MAX III G enclosures will not be heated above 75° Celsius.
2. Mount the V-MAX III G Series receiver antenna pointing toward and in direct line-of-sight to where the V-MAX III G Series transmitter antenna will be located at the other end of the link. Insure that no obstacles break the line-of-sight even temporarily. Make sure that the receiver's frequency is set to the same frequency as the transmitter. Mount as high as possible to avoid RF reflections (multipath). Mount at least 10 feet away from any other antennas near the same frequency band.
3. Connect an appropriate video monitor via a 75 Ω coaxial cable to the V-MAX III G Series receiver's video output. Terminate monitor if necessary. Power-up the V-MAX III G Series receiver and make sure that there is "VIDEO SNOW" on the monitor. "VIDEO SNOW" is black and white specs appearing on the screen of the monitor. If there are black and white lines in the picture, or any other patterns of dots that do not match the description of "VIDEO SNOW", change the receiver's frequency until any interference is eliminated or minimized.
4. Mount the V-MAX III G Series transmitter antenna pointing toward and in direct line-of-sight to the V-MAX III G Series receiver at the other end of the link. Insure that no obstacles break the line-of-sight even temporarily. Mount as high as possible to avoid RF reflections (multipath). Mount at least 10 feet away from any other antennas near the same frequency band.
5. Connect the V-MAX III G Series receiver's BNC video output to the permanent system video monitor via a 75 Ω coaxial cable. Connect an appropriate camera or other video source via a 75 Ω coaxial cable to the V-MAX III G Series transmitter's BNC video input.
6. Apply 85 to 230 VAC power to both the transmitter and the receiver. Verify that the video link is operational.
7. Secure the door on each NEMA-4X non-metallic enclosure to ensure an environmental seal.

32 CHANNEL TRANSMITTER AND RECEIVER SETTINGS

CHANNEL	DIAL	JUMPER	FREQUENCY	CHANNEL	DIAL	JUMPER	FREQUENCY
1			5.732 GHz	17			5.876 GHz
2			5.741 GHz	18			5.885 GHz
3			5.750 GHz	19			5.894 GHz
4			5.759 GHz	20			5.903 GHz
5			5.768 GHz	21			5.912 GHz
6			5.777 GHz	22			5.921 GHz
7			5.786 GHz	23			5.930 GHz
8			5.795 GHz	24			5.939 GHz
9			5.804 GHz	25			5.660 GHz
10			5.813 GHz	26			5.669 GHz
11			5.822 GHz	27			5.678 GHz
12			5.831 GHz	28			5.687 GHz
13			5.840 GHz	29			5.696 GHz
14			5.849 GHz	30			5.705 GHz
15			5.858 GHz	31			5.714 GHz
16			5.867 GHz	32			5.723 GHz

32 CHANNEL TRANSMITTER AND RECEIVER SETTINGS

CHANNEL	DIAL	JUMPER	FREQUENCY	CHANNEL	DIAL	JUMPER	FREQUENCY
1			5.732 GHz	17			5.876 GHz
2			5.741 GHz	18			5.885 GHz
3			5.750 GHz	19			5.894 GHz
4			5.759 GHz	20			5.903 GHz
5			5.768 GHz	21			5.912 GHz
6			5.777 GHz	22			5.921 GHz
7			5.786 GHz	23			5.930 GHz
8			5.795 GHz	24			5.939 GHz
9			5.804 GHz	25			5.660 GHz
10			5.813 GHz	26			5.669 GHz
11			5.822 GHz	27			5.678 GHz
12			5.831 GHz	28			5.687 GHz
13			5.840 GHz	29			5.696 GHz
14			5.849 GHz	30			5.705 GHz
15			5.858 GHz	31			5.714 GHz
16			5.867 GHz	32			5.723 GHz

TROUBLESHOOTING

PROBLEM: *No Picture*

POSSIBLE CAUSES

- Are the AC outlets live? Verify with a VOM or circuit tester. Is Power connected to the transmitter, receiver, monitor, and camera?
- Are all of the system components connected and powered up? Re-check all of component connections.
- Is the receiver video cable connected?
- Are the transmitter and receiver on the same channel/frequency? Check the channel select switches on the receiver.

PROBLEM: *Unstable Picture*

POSSIBLE CAUSES

- Are the transmitter and receiver mounted less than 20 feet apart? If so, relocate the transmitter and receiver to at least 20 feet distance between the units.
- Are multiple receive antennas installed less than 5 feet apart? If so, relocate at least one of the antennas to insure at least 5 feet of separation.

PROBLEM: *Transmission Range Reduced*

POSSIBLE CAUSES

- Is the height of either transmit or receive antenna less than 30 feet above ground or less than 10 feet above the roof line? If so, elevate the transmit and/or receive antenna(s) so that a clear line-of-sight is maintained between the antennas.
- Make sure that the antennas are pointed directly at each other.
- Relocate the transmit antenna, if necessary, away from any large metal surfaces that may cause interference and/or reduce range.

SPECIFICATIONS

The V-MAX III G 5.8 GHZ Video System includes: (1) Video Transmitter, Integral Transmitter Antenna, (1) Video Receiver, (1) Receiver Antenna, (2) AC/DC Power Adapters, (1) Installation/Operations Manual, (2) Pole Mount Brackets and Mounting Hardware.

WIRELESS TECHNOLOGY: V-MAX III G TX-5800

Power Input Voltage	85-230 VAC or 115 VAC with thermostatically controlled heater (115 VAC), 50/60 Hz @ 1.5 amp
Max. Current Draw	300 mA
Transmitter Frequency	5660-5939 MHz
Frequency Accuracy	50 ppm - 20° C to +45° C
Effective Radiated Power	50,000 Micro-Volts/Meter
Transmitter Attack Time	Less than 10 m/sec.
Spurious & Harmonics	Less than -60 dBc
Modulation	FM Video
Pre-Emphasis Complies to	ITR and CCIR, 405-1
Antenna	Linear-polarized microstrip, beamwidth 120°
Range	Up to 2 miles
Video Compatibility	Broadcast Standard Color & B&W, EIA-250-C

WIRELESS TECHNOLOGY: V-MAX III G RX-5800

Power Input Voltage	85-230 VAC or 115 VAC with thermostatically controlled heater (115 VAC), 50/60 Hz @ 1.5 amp
Max. Current Draw	350 mA
Receiver Frequency	5660-5939 MHz
Receiver Sensitivity	-80 dBm for 40 dB - S/N
Receiver Accuracy	0.02%, -20° C to +45° C
Spurious & Harmonics	Less than -80 dBc

SPECIFICATIONS

Noise Figure (Total System)	Less than 3 dB
Video Bandwidth	12 MHz
Video Output	NTSC/PAL Standard, EJA-250-C, 1.0 V P-P
Antenna Gain/Beamwidth	28 dBI / 7°

INPUTS

Transmitter

Video: BNC connector that accepts a standard NTSC/PAL composite video signal (1.0 V P-P), 75Ω input impedance.

Receiver

Long Range RF Input Antenna: N Female connector, mates with connector on antenna provided.

OUTPUT

Video Monitor: BNC Connector, NTSC/PAL Standard Output, EIA-250-C, 1.0 V P-P; 75Ω.

POWER

Terminal strip connector with wire clamps for each terminal.

DIMENSIONS:

Weight: 8 lbs.

Size: 9.3" W X 11.3" H X 5.3" D

Weatherproof NEMA-4X non-metallic enclosure provided with a mast mount bracket (2" diameter mast, minimum size)

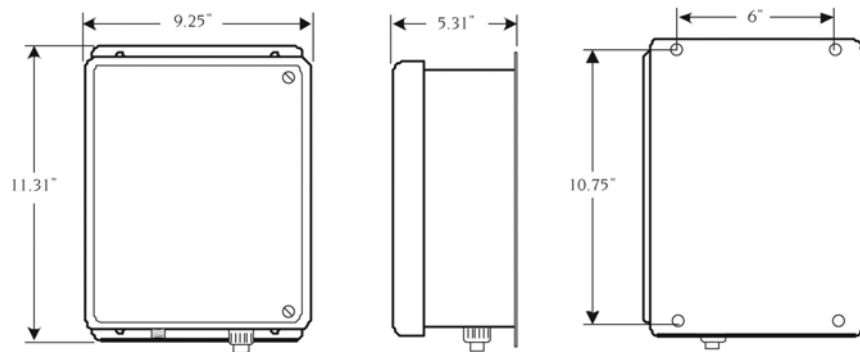

MADE IN USA

US PATENT # 5,128,755 • CONFORMS TO EIA-TIA-250-C

See the Wireless Camera Control Product Sheets for Pan/Tilt/Zoom, Multiplexer and Camera Control Options. Due to Wireless Technology, Inc. (WTI) continuing efforts to engineer the best product that is most responsive to our customer's needs, the above specifications are subject to change without notice.

All products are trademarks or registered trademarks of their respective holders. The use of these marks does not suggest any association between these companies.

SPECIFICATIONS



MODEL: DA-5824
Parabolic Dish Antenna

The rugged aluminum reflector and prime focus T-feed offer exceptional reliability at an affordable price. The 5.8 GHz antenna's optimized dipole feed delivers superior pattern performance and has a subreflector built directly into the feed.

These antennas provide excellent electrical performance mated with a rugged mechanical design to deliver a high value solution to your antenna requirements.

FEATURES

- Professional grade durability ensures installation longevity.
- Lightweight construction and integrated design minimizes installation time.
- Exceptional pattern performance ensures optimized link budgets.
- Antenna blends into the horizon.

ELECTRICAL		MECHANICAL	
Frequency	5700-5875 MHz	Output Connector	"N" type male/female
Gain	23 +/- 1 dBi	Mounting O.D. Pipe	1.25" - 2.375" (32-60 mm)
Polarization Isolation	>25 dB	Vertical Tilt	
Side lobe Suppression	>18 dB	Top Pole Mount	0-66°
3dB Beamwidth	7°	Side Pole Mount	0-22°
10dB Beamwidth	13°	Wind Load @ -30°F	
Front/Back Ratio	>30 dB	Operational	80 mph, 43.4 lbs (19.7 kg)
VSWR Typical	1.8:1	Survivable	140 mph, 133 lbs (60.5 kg)
Pigtail Extension	RG8 13"	Reflector Type	Spun aluminum parabolic
		Reflector Material	Powder coated aluminum
		Reflector Color	Light gray
		Dimensions	16" x 10" (0.406 m x 0.254 m)
		Weight	
		Antenna	1.8 lbs. (0.81 kg)
		Mount	1.5 lbs. (0.68 kg)

MADE IN THE USA • 2 Year Warranty

Due to Wireless Technology, Inc. (WTI) continuing efforts to engineer the best product that is most responsive to our customer's needs, the above specifications are subject to change without notice.

All products are trademarks or registered trademarks of their respective holders. The use of these marks does not suggest any association between these companies.

SPECIFICATIONS



MODEL DA-5830 Parabolic Dish Antenna



The rugged prime focus parabolic reflector and prime focus T-feed offer exceptional reliability at an affordable price. The 5.8 GHz antenna's optimized dipole feed delivers superior pattern performance and has a subreflector built directly into the feed.

These antennas provide excellent electrical performance mated with a rugged mechanical design to deliver a high value solution to your antenna requirements.

FEATURES

- Professional grade durability ensures installation longevity.
- Lightweight construction and integrated design minimizes installation time.
- Exceptional pattern performance ensures optimized link budgets.
- Antenna blends into the horizon.

ELECTRICAL		MECHANICAL	
Frequency	5700-5875 MHz	Output Connector	"N" type female
Gain	30 +/- 1 dBi	Mounting O.D. Pipe	1.25" - 2.375" (32-60mm)
Polarization Isolation	>25 dB	Vertical Tilt	
Side lobe Suppression	>18 dB	Top Pole Mount	0-66o
3dB Beamwidth	6°	Side Pole Mount	0-22o
10dB Beamwidth	12°	Wind Load @ -30° F	
Front/Back Ratio	>35 dB	Operational	80 mph, 43.4 lbs (19.7 kg)
VSWR Typical	1.8:1	Survivable	140 mph, 133 lbs (60.5 kg)
Pigtail Extension	RG8 13"	Reflector Type	Spun aluminum parabolic
		Reflector Material	Powder coated aluminum
		Reflector Color	White on white
		Dimensions	24" (0.406 m)
		Weight	9 lbs. (4.08 kg)

MADE IN THE USA • 2 Year Warranty

Due to Wireless Technology, Inc. (WTI) continuing efforts to engineer the best product that is most responsive to our customer's needs, the above specifications are subject to change without notice.
All products are trademarks or registered trademarks of their respective holders. The use of these marks does not suggest any association between these companies.



www.gotowti.com

An ISO 9001:2000 Certified Company



Wireless Technology, Inc. (WTI)
2064 Eastman Avenue, Suite 113
Ventura, CA 93003-7787 USA
tel 805/339-9696 • fax 805/339-0932 • email: sales@wirelesstech.com
www.gotowti.com

Due to Wireless Technology, Inc. (WTI) continuing efforts to engineer the best product that is most responsive to our customer's needs, the above specifications are subject to change without notice.
All products are trademarks or registered trademarks of their respective holders. The use of these marks does not suggest any association between these companies.