



www.gotowti.com

An ISO 9001:2000 Certified Company



Wireless Technology, Inc.

**SHORT RANGE
TRANSMISSION SYSTEMS**

**SR5805-8 • SR5815-8 • SR5840-8
12VDC**

*Installation and
Operation Manual*

Table of Contents

INFORMATION	<i>Page 3</i>
PRODUCT WARRANTY AND REPAIRS	<i>Page 4</i>
SAFEGUARDS AND TOOLS	<i>Page 6</i>
MODELS <i>and</i> OPTIONS	<i>Page 7</i>
INSTALLATION	<i>Page 9</i>
TROUBLE SHOOTING	<i>Page 11</i>
TECHNICAL SPECIFICATIONS	<i>Page 12</i>

INFORMATION

FCC NOTICE

This device complies with Part 15 of the FCC Rules.

Operation is subject to the following two conditions:

- 1.) This device may not cause harmful interference.
- 2.) This device must accept any interference that may be received, including interference that may cause undesired operation.

READ THIS MANUAL

Every effort has been made to insure that this WTI system is of the highest quality. This product has been carefully inspected to comply with rigid quality standards before shipment to you. In consideration of your investment and the desire to obtain full performance capability engineered into your new WTI product, we recommend that you read this manual before attempting to operate your system.

FOR MORE ASSISTANCE OR MORE INFORMATION:

Wireless Technology, Inc. (WTI)
2064 Eastman Avenue, Suite 113
Ventura, CA 93003-7787

TEL. 805/339-9696

FAX. 805/339-0932

EMAIL: sales@wirelesstech.com

INTERNET: <http://www.gotowti.com> or
<http://www.wirelesstech.com>

The software / firmware furnished with the equipment is confidential to and is copyrighted by *Wireless Technology, Inc.* (WTI). It is not to be copied or disclosed in any manner without the consent of *Wireless Technology, Inc.* (WTI). The software/firmware is furnished to the purchaser under a license for use on a single system.

Information furnished by *Wireless Technology, Inc.* (WTI) is believed to be accurate and reliable. However, no responsibility is assumed by *Wireless Technology, Inc.* (WTI) for its use or for any infringements of other rights of third parties, which may result from its use. No license is granted by implications or otherwise under any patent or patent rights of *Wireless Technology, Inc.* (WTI).

©2008 Wireless Technology, Inc. (WTI)
All rights reserved.

PRODUCT WARRANTY AND REPAIR

PRODUCT WARRANTY

We appreciate your purchase of *Wireless Technology, Inc.* (WTI) security products. We take pride in the quality of our products and have manufactured each new WTI product to exacting quality standards. In normal use, it will provide you with years of satisfactory performance. However, should you experience difficulty; you are protected under the provisions of this warranty.

WTI warrants to the original user a product that is free of defects in materials and workmanship in normal use. WTI warrants to the original user that WTI's wireless RF transmission system products will be free of defects in materials and workmanship in normal use for a period of 12 months from the date of sale. WTI's obligation under this warranty shall be limited to the repair, including all necessary parts and the cost of labor connected therewith, or at our option, the replacement of any product that shows evidence of a manufacturing defect within the warranty period.

This warranty is extended to all WTI products purchased and used within the United States of America and is valid only when service is rendered by the authorized *Wireless Technology, Inc.* (WTI) Warranty Station.

This warranty shall not apply to appearance or accessory items including, but not limited to, knobs, connectors, cabinets and connecting cables. This warranty shall not, in addition, apply to repairs or replacements necessitated by any cause beyond the control of WTI including, but not limited to, acts of nature, improper installation, misuse, lack of proper maintenance, accident, voltage fluctuations, unauthorized repairs or modifications.

This warranty becomes void in the event serial numbers are altered, defaced or removed, or an attempt is made to field service or alter performance of any RF transmission component.

WTI reserves the right to make changes in design, or to make additions to, or improvements upon, products without incurring any obligation to install the same on products previously manufactured.

The foregoing is in lieu of all other warranties expressed or implied and WTI neither assumes nor authorizes any person to assume for it any other obligation or liability in connection with the sale of our products. In no event shall WTI or its Authorized Dealers be liable for special or consequential damage arising from the use of this product, or any delay in the performance of this warranty due to causes beyond its control.

PRODUCT WARRANTY AND REPAIR

REPAIR AUTHORIZATION

Please contact *Wireless Technology, Inc.* (WTI), to obtain a repair authorization number (RA) and provide the following information:

- 1.) Product Model & Serial Numbers
- 2.) Date of shipment, purchase order number, sales order number or WTI invoice number.
- 3.) Details of the defect or malfunction. If there is a dispute regarding the warranty or product, which does not fall under the warranty conditions stated within the description of the written warranty, please include a written explanation with the product when returned.

SHIP FREIGHT PRE-PAID TO:

Wireless Technology, Inc. (WTI)
2064 Eastman Avenue, Suite 113
Ventura, CA 93003-7787
TEL 805/339-9696
FAX 805/339-0932

RETURNS

No unauthorized returns will be accepted. All returns must have an authorized (RA) number issued by the factory (CA number if returned for credit and RA number if returned for repair). Products returned for repair or credit will be rejected if no authorization number has been issued or freight has not been pre-paid. All merchandise returned for credit will be subject to a 20% restocking and refurbishing charge.

SAFEGUARDS AND TOOLS

IMPORTANT SAFEGUARDS

- 1.) Read Instructions. It is important to read all safety and operating instructions before installing or using this equipment.
- 2.) Retain Instructions. Retain this manual and any supplements for future reference.
- 3.) Follow Instructions. Follow all instructions herein for use of this equipment.

Do not attempt to open the sealed Transmitter or Receiver Assembly. There are no user-serviceable parts inside. Refer servicing to the WTI factory service center only.

- 4.) Heed all warnings. Adhere to all warnings on the equipment, and in this manual.
- 5.) To reduce the risk of electric shock or equipment damage, work on the unit only when the power is shut off and is unplugged from its power source to prevent accidental activation. Also take precautions to avoid contact between the equipment and other electrical wires or power sources that may be present at the installation site.

RECOMMENDED TOOLS AND ACCESSORIES FOR PROPER INSTALLATION:

- 1.) Tie-wraps to secure cable runs
- 2.) Phillips screwdriver
- 3.) Slot screwdriver
- 4.) Cordless power drill
- 5.) Set of open end or SAE wrenches
- 6.) Silicone caulking compound for antenna connector
- 7.) Self-sealing connector tape - Used to weatherproof all outdoor cable connections
- 8.) 3/4" PVC flex conduit if boxes are mounted outdoors
- 9.) Hand held radios

Wireless Technology, Inc. recommends the use of RG59/U such as Belden 8241 or equivalent 75Ω coaxial cable with 22-gauge solid copper center conductor and foam polyethylene dielectric. Either RG6/U or RG11/U would make an excellent substitute.

Long coaxial cable runs cause signal degradation and/ or "SYNC" discrepancies. Limit RG59/U cable lengths to 800 feet. For coaxial runs from 800 feet to 1000 feet, use RG6/U or RG11/U.

Do not use screw on type BNC connectors. They are not suited for reliable installations.

MODELS *and* OPTIONS

SR-5800-8 SERIES TRANSMISSION SYSTEMS

When conventional cable installations are impractical or impossible, the SR-5800-8 Short Range Fixed Site Systems provide high quality, real-time wireless video transmission and reception. The SR-5800-8 provides exceptional performance throughout all climates and is not affected by fog, rain or snow.

SR-5800-8 SERIES FEATURES

- Eight field-selectable channels of operation.
- LED power light on both transmitter and receiver.
- 12 VDC or (optional) 24 VAC operation
- Utilizes high-technology microstrip antennas.
- Channel lock VCO.
- Optional thermostatically controlled heater.
- No user license required.

SR-5805-8

This system is for short-range transmission up to 500 feet. The SR-5805-8 utilizes an internal, single-element microstrip antenna on both the transmitter and the receiver.

SR-5815-8

This system is for short-range transmission up to 1500 feet. The SR-5815-8 transmits with an internal, single-element microstrip antenna and receives with an internal, 16 element, phased-array, microstrip antenna.

SR-5840-8

This system is for transmission up to 4000 feet. The SR-5840-8 transmits with an internal, 16 element, phased-array, microstrip antenna and receives with an internal, 16 element, phased-array, microstrip antenna.

SR-5800-8 SERIES 24 VAC POWER OPTION

The SR-5800-8 series of transmitters and receivers are available with a 24 VAC power option. This option includes two 24 VAC 40VA Wall Transformer modules for the transmitter and receiver.

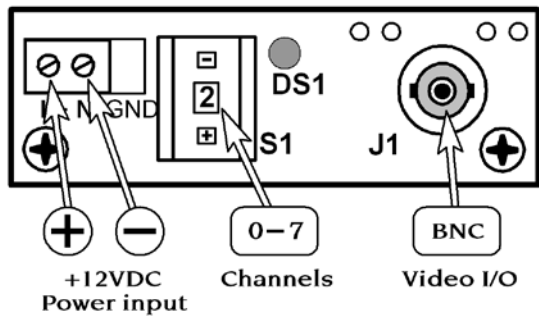
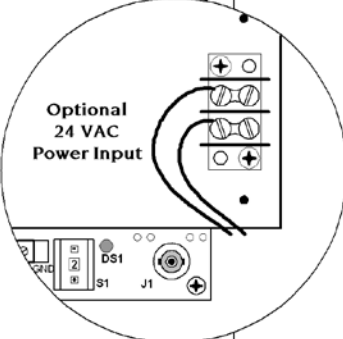
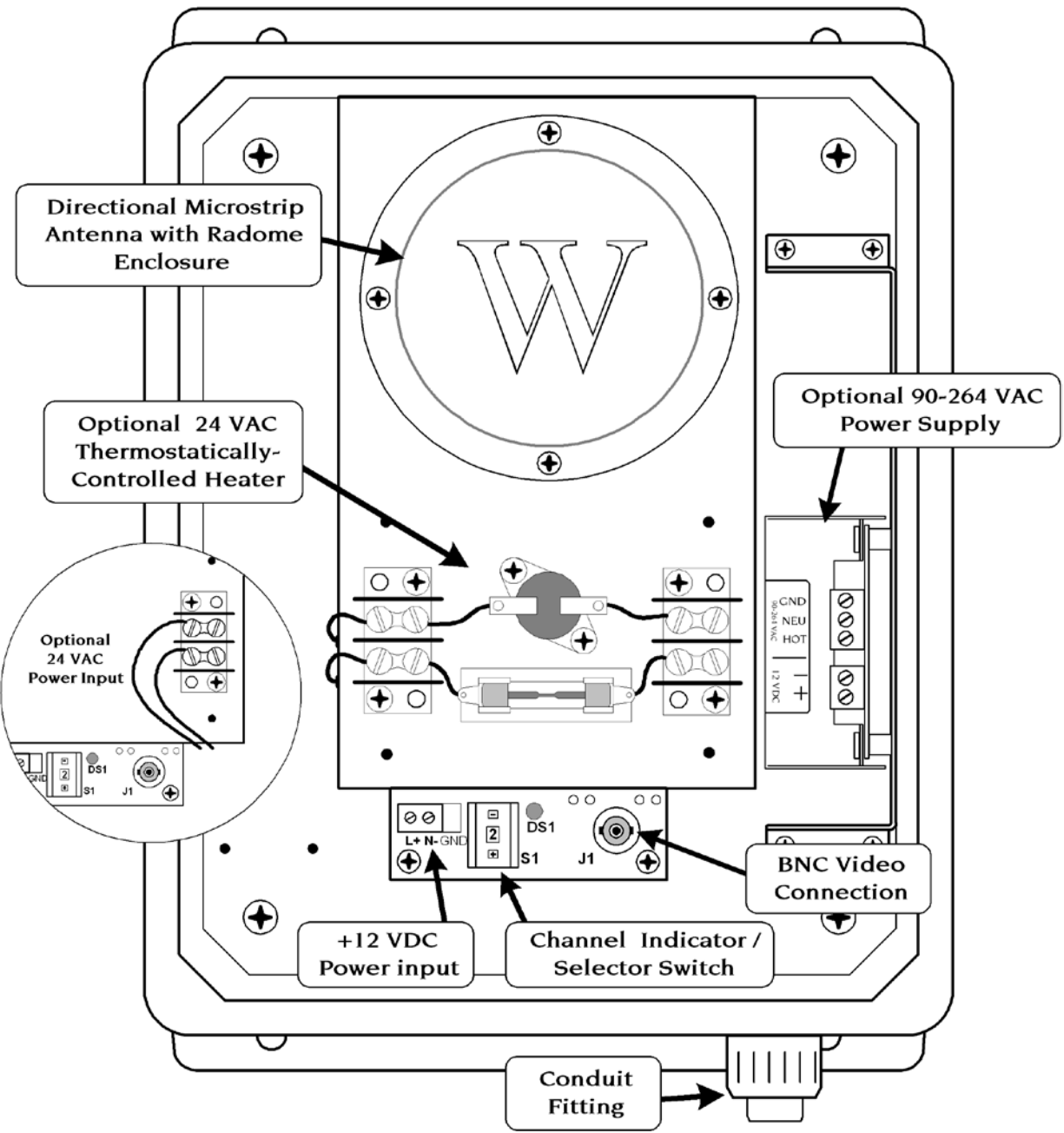

INSTALLATION

1.) Mount the SR-5800-8 Series receiver antenna pointing toward and in direct line-of-sight to the SR-5800-8 Series transmitter at the other end of the link. Insure that no obstacles break the line-of-sight even temporarily. Mount as high as possible to avoid RF reflections (multi-path). Mount at least 10 feet away from any other antennas near the same frequency band.

Note: Always mount the SR-5800-8 Series transmitter and receiver enclosures away from electronically noisy items. Insure that the SR-5800-8 enclosures will not be heated above 60 degrees Celsius (140 degrees Fahrenheit).

2.) Connect an appropriate video monitor via a 75 Ω coaxial cable to the SR-5800-8 Series receiver's video output. Terminate the monitor cable if necessary.

3.) Apply 12 VDC (or optional 24 VAC) power to the receiver. Standard 18 gauge power wiring should be used for 12 VDC SR-5800-8 models. If the 24 VAC option is being used, refer to the table below to determine the wire gauge necessary for the length of cable being used. Verify that the power LED indicator is on after the power is connected.

4.) Observe the video image and make sure that there is "VIDEO SNOW" on the monitor. "VIDEO SNOW" is black and white specs appearing on the screen of the monitor. If there are black and white lines in the picture, or any other patterns of dots that do not match the description of "VIDEO SNOW", change the RF channel using the two pushbuttons above and below the channel number indicator until any interference is eliminated or minimized. The eight available receiving channels are numbered 0 through 7.

Note: Channels 8 and 9 are not available, and setting the channel selector switch to these positions may cause unpredictable operation.

5.) Mount the SR-5800-8 Series transmitter antenna pointing toward and in direct line-of-sight to the SR-5800-8 Series receiver at the other end of the link. Insure that no obstacles break the line-of-sight even temporarily. Mount as high as possible to avoid RF reflections (multi-path). Mount at least 10 feet away from any other antennas near the same frequency band. Make sure that the transmitter RF channel is set the same as the receiver. The eight available transmit channels are numbered 0 through 7.

Note: Channels 8 and 9 are not available, and setting the channel selector switch to these positions may jam other channels that are in use or cause unpredictable operation.

6.) Connect the camera or other video source to the SR-5800-8 transmitter input via a 75 Ω coaxial cable. Verify that the image from the camera or other video source is now visible on the receiver monitor, and that the image is clear, and free of excessive noise or interference.

7.) Secure the door on each NEMA 4X non-metallic enclosure to ensure an environmental seal.

INSTALLATION

8.) The following guidelines should be observed for power cable selection when using the 24 VAC power option, in order to insure that the voltage at the transmitter or receiver is sufficient to provide reliable operation. The 24 VAC power supply wiring may be solid or stranded, twisted pair or common "ZIP" cord.

<i>Wire Gauge (AWG #)</i>	<i>Maximum Cable Length for 24VAC Power w/o Heater</i>	<i>Maximum Cable Length for 24VAC Power with Heater</i>
20	165	35
18	265	55
16	425	85
14	675	135
12	1050	220
10	1700	350

Note: These numbers are based on a worst case power line voltage of 95VAC and a minimum module input voltage of 20 VAC, using the 24 VAC Wall Transformer modules supplied by WTI with the 24 VAC option.

TROUBLESHOOTING

PROBLEM: *No Picture*

POSSIBLE CAUSES

- Are the AC outlets live? Verify with a VOM or circuit tester. Is Power connected to the transmitter, receiver, monitor, and camera?
- Are all of the system components connected and powered up? Recheck all of component connections.
- Is the receiver video cable connected?
- Are the transmitter and receiver on the same channel/frequency? Check the channel selection switch numbers on the transmitter and receiver. Verify that neither the transmitter nor the receiver is set to channel 8 or 9.

PROBLEM: *Unstable Picture*

POSSIBLE CAUSES

- Are the transmitter and receiver mounted less than 20 feet apart? If so, relocate the transmitter or receiver so that there is at least 20 feet between the units.
- Are multiple receive antennas installed less than 5 feet apart? If so, relocate at least one of the antennas to insure at least 5 feet of separation.
- If using the 24 VAC option, is the AC voltage at the power input terminals of either of the units under 20 VAC? If so, refer to the Cable Length chart on Page 10 of this manual and check to see that the proper gauge wire has been selected for the length of power cable in use. Use only *Wireless Technology* approved 24 VAC power supplies.

PROBLEM: *Transmission Range Reduced*

POSSIBLE CAUSES

- Is the height of either transmit or receive antenna less than 30 feet above ground or less than 10 feet above the roof line? If so, elevate the transmitter and/or receiver antenna(s) so that a clear line-of-sight is maintained between the antennas.
- Make sure that the antennas are pointed directly at each other.
- Relocate the transmit antenna, if necessary, away from any large metal surfaces that may cause interference and/or reduce range.

PROBLEM: *Hum in Picture*

POSSIBLE CAUSE

- Use only *Wireless Technology* approved power supplies for the 12 VDC or 24 VAC option. *Wireless Technology* supplies 12 VDC or 24 VAC power supplies with the video transmission system.

SPECIFICATIONS

TRANSMITTER – TX:

Power Options	12VDC @ 500mA wall transformer (standard) or 85-264VAC, 50/60Hz, 25 watts
Heater Model Power Options	24VAC @ 1.4A wall transformer (standard) or 85-264VAC, 50/60Hz, 40 watts
Frequency Band	5.732 GHz to 5.867 GHz
Frequency Accuracy	50 ppm, -20° to +45° C
Effective Radiated Power	50,000 micro-volts/meter
Transmitter Attack Time	Less than 5 m sec.
Spurious & Harmonics	Less than -60 dBc
Modulation	FM video
Pre-Emphasis	Complies to ITR and CCIR, 405-1
Transmitter Antenna	Gain + 3dBdl, microstrip, beamwidth 160°

RECEIVER – RX:

Power Options	12VDC @ 500mA wall transformer (standard) or 85-264VAC, 50/60Hz, 25 watts
Heater Model Power Options	24VAC @ 1.4A wall transformer (standard) or 85-264VAC, 50/60Hz, 40 watts
Receiver Input Sensitivity	-70 dBm
Receiver Accuracy	0.02%, -20° C to +45° C
Spurious & Harmonics	Less than -60 dBc
Noise Figure (total system)	<4 dB
Video Output Level	75Ω @ 1.0 V P-P

ANTENNAS:

RX5805	Gain +3 dBdl, microstrip, beamwidth 70°
RX5815	Gain +12 dBdl, microstrip, beamwidth 22°
RX5840	Gain +24 dBdl, microstrip, beamwidth 14°

INPUT / OUTPUT

Video output: standard NTSC or PAL composite video signal (1.0V P-P), 75Ω input impedance, BNC female connector.

POWER

Phoenix contact P/N 1757019

DIMENSIONS

Weight: 6 lbs.

Size: 9.3" (23.6cm) W x 11.3" (28.7cm) H x 5.3" (13.5cm) D

Weatherproof NEMA 4X non-metallic enclosure provided with a mast-mounted bracket (2" diameter mast, minimum size).



www.gotowti.com

An ISO 9001:2000 Certified Company

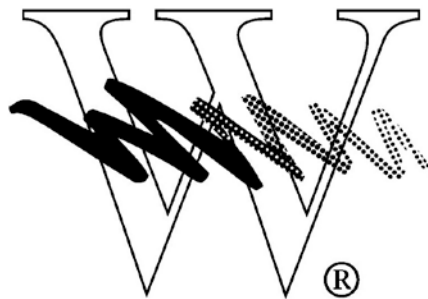

Wireless Technology, Inc.

Wireless Technology, Inc. (WTI)
2064 Eastman Avenue, Suite 113
Ventura, CA 93003-7787 USA
tel 805/339-9696 • fax 805/339-0932 • email: sales@wirelesstech.com
www.gotowti.com • www.wirelesstech.com

Due to Wireless Technology, Inc. (WTI) continuing efforts to engineer the best product that is most responsive to our customer's needs, the above specifications are subject to change without notice.